

Double Dex — Custom Solutions for Customer Needs

FROM GREAT DANE

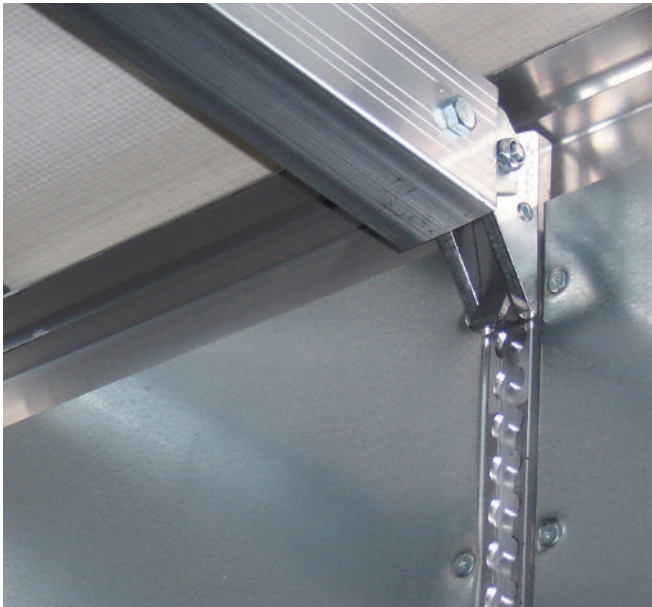

Double-decking freight has become a popular way to increase profits by maximizing useable trailer cube. That's why Great Dane has developed **Double Dex** — an innovative technology that creates a second deck to accommodate additional cargo. By using captive beams with a recessed track, this system can help to improve load average and increase revenue per mile!

In addition to providing more cube, **Double Dex** also reduces cargo damage. Typical captive beam systems are attached to the trailer sidewall or post, leaving the supports for the beams exposed. These protruding supports snag and damage freight as well as increase maintenance costs on the trailer. But **Double Dex** is different! As a factory-installed option, this innovative design allows the cargo track to be entirely recessed into the post providing a virtually snag-free area. Plus, the beams used in this system lock into place at the extreme top of the trailer, providing an additional 2.31" of overhead clearance as compared to the competition.

Great Dane has made significant strides in the manufacturing and performance of trailers. We take pride in developing custom solutions to meet our customers' challenges and needs.



Double Dex's innovative design creates a second deck to help maximize utilization of the trailer.

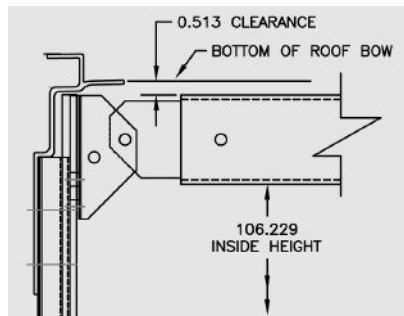

Offers more cubic capacity as well as 2.312" more clearance.



Reduces cargo damage by using recessed fasteners so there are no protruding heads that can snag freight.

GREAT DANE. AHEAD OF THE INDUSTRY.
BEHIND YOU ALL THE WAY.



Great Dane

A Division of Great Dane Limited Partnership

www.greatdanetrailers.com